



CERAMETAL



**MODULAR CARTRIDGE SYSTEM
FOR TOOL SECTION 40 AND 50**

**MODULARES KASSETTENSYSYSTEM FUER
WERKZEUGE MIT DEN ABMASSEN 40 UND 50**

**SYSTEME MODULAIRE A CARTOUCHES
POUR OUTILS DE SECTION 40 ET 50**



CARTRIDGES : Assembly description
KASSETTEN : Allgemeine Beschreibung des Aufbaus
CARTOUCHES: Description du montage

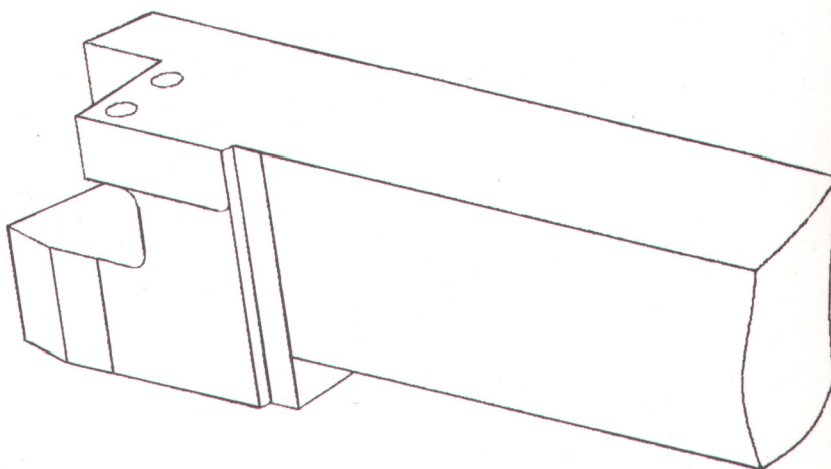
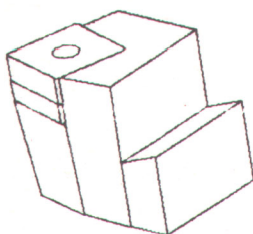

Advantages	Vorteile	Avantages
<ul style="list-style-type: none"> - Allows most appropriate insert selection for operation to be done. - Rapid an easy change of the cartridges. - Rigidity and precision. - Makes the use of different cutting materials possible. - Can be set directly on the existing toolholder without any modification of the turret. <p><u>Use</u> : On most vertical and horizontal medium lathes, using toolholder section 40 and 50.</p>	<ul style="list-style-type: none"> - Erlaubt die Auswahl der geeigneten Platte für bestimmte Arbeiten. - Einfaches und schnelles Wechseln der Kassette. - Stabiler und genauer Einbau (Auflageflächen geschliffen). - Einsatz verschiedener Schneidstoffe möglich (Hartmetall, Keramik, CBN...). - Ersetzbar am Werkzeug ohne Änderung am Revolverkopf. <p><u>Gebrauch</u> : Hauptsächlich vertikale und horizontale Drehbänke mit Werkzeughaltern mit den Ausmaßen 40 und 50.</p>	<ul style="list-style-type: none"> - Permet la sélection de la plaq. la plus appropriée au travail effectué - Chgt. simple et rapide des cartouches - Montage robuste et précis (surfaces d'appui rectifiées) - Permet l'emploi de divers matériaux de coupe (carbure, céramique,CBN,...) - Se substitue directement à l'outil existant sans modification au niveau de la tourelle <p><u>Utilisation</u> : La plupart des tours verticaux ou horizontaux moyens utilisant des porte-outils de section 40 et 50.</p>



CERAMETAL

INDEX INHALTSZEICHNIS

TOOLHOLDER
WERKZEUGHALTER
PORTE-OUTIL

1

Cartridge
Kassette
Cartouche

Insert
WSP
Plaquette

Tool cutting edge angle
Einstellwinkel
Angle de dir. d'arête de
l'outil

R

L

C 32940 C 33546 C 32941	C 33532 C 33547 C 33535	CNM. 1204. CNM. 1606. CNM. 1906.	95° A + R	2
C 33533 C 33635 C 33530	C 33534 C 33636 C 33531	CNM. 1204. CNM. 1606. CNM. 1906.	75° A	3
C 35738	C 35737	DNM. 1506.	93° A	4
C 33555 C 33548 C 33526	C 33556 C 33549 C 33527	SNM. 1204. SNM. 1506. SNM. 1906.	75° A	5
C 33536	C 33537	SNM. 1906.	75° R	6
C 32942	C 33538	SNM. 1906.	45° A + R	7
C 32946	C 33545	SNM. 1906.	45° R	8
C 33528	C 33529	SCM. 1205.	45° A + R	9
C 32943 C 32943-3 C 32944	C 33600 C 33600-3 C 33543	TNM. 1604. TNM. 1603. TNM. 2204.	90° R	10
C 32939 C 33408	C 33407 C 33409	RCM. 2006. RCM. 2507.		11
C 33410-4 C 33410 C 33410-3	C 33411-4 C 33411 C 33411-3	RNGN. 1204. RNGN. 1207. RNGN. 1203.		12
C 33541-4 C 33541	C 33542-4 C 33542	TNGN. 1604. TNGN. 1607.		13
C 33539 C 33539-3	C 33540 C 33540-3	SNGN. 1207. SNGN. 1203.	75° A	14
C 33740 C 35740-3	C 35739 C 35739-3	SNGN. 1207. SNGN. 1203.	45° A	15
C 32945	C 33544	WNMG. 0804.	95° A + R	16

TOOLHOLDER - WERKZEUGHALTER - PORTE-OUTIL

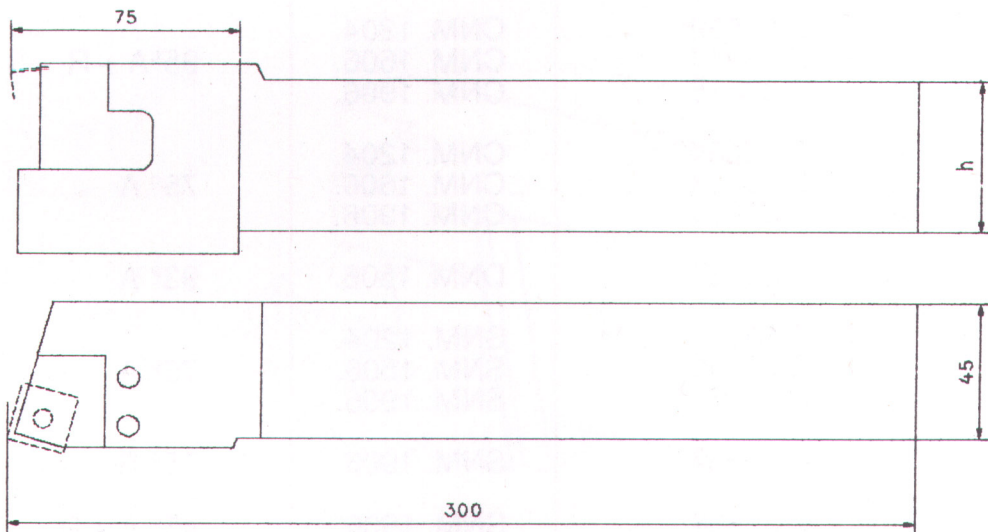

FOR FÜR POUR	h	ORDER NUMBER BESTELLNUMMER No DE COMMANDE	
		Right Execution	Left Execution
	40	C 32 938	C 33 406
	50	C 33 524	C 33 525

- Mounting screw for cartridge : C 23 130
- Spanschraube für Kassette : C 23 130
- Vis de pression pour la cartouche : C 23 130

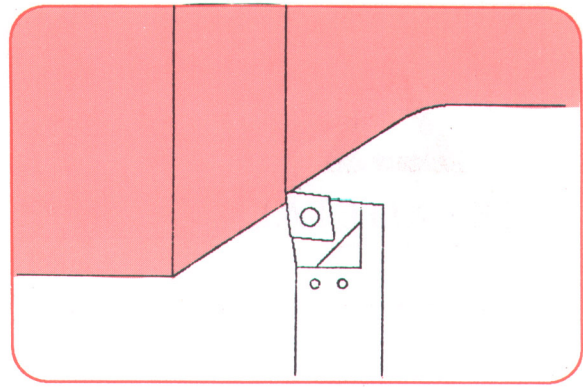

CARTRIDGE - KASSETTE - CARTOUCHE

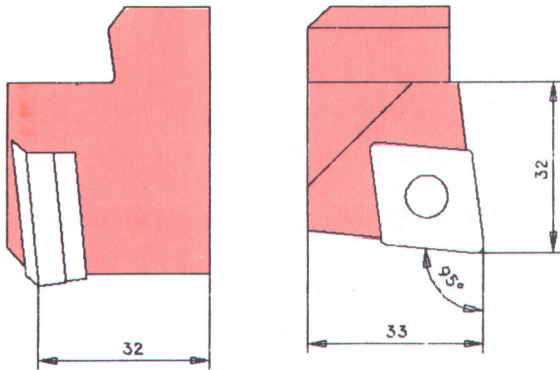

Right hand shown

APPLICATION : Copy turning

ANWENDUNG : Kopierdrehen

UTILISATION : Copiage

FOR INSERT
FÜR WENDEPLATTE
POUR PLAQUETTE

ORDER NUMBER
BESTELLNUMMER
NO DE COMMANDE

	RIGHT EXECUTION		LEFT EXECUTION	
CNM . 12 04..	C 32940	●	C 33532	●
CNM . 16 06 ..	C 33546	●	C 33547	●
CNM . 19 06 ..	C 32941	●	C 33535	●



Usually on stock - Gewöhnlich auf Lager
Habituellement de stock



On request - Auf Anfrage
Sur demande

SPARE PARTS - ERSATZTEILE - PIECES DETACHEES

FOR INSERT
FÜR WENDEPLATTE
POUR PLAQUETTE



CNM . 12 04..	32 073	32 204	C 26372
CNM . 16 06..	32 075	32 205	C 26373
CNM . 19 06..	32 076	32 206	C 26374

- Mounting screw for cartridge : C 23130
- Spanschraube für Kasette : C 23130
- Vis de pression pour la cartouche : C 23130

- For insert choice see Céramétal turning catalogue
- Für Plattentyp siehe Céramétal Drehkatalog
- Pour le choix des plaquettes voir le catalogue tournage Céramétal

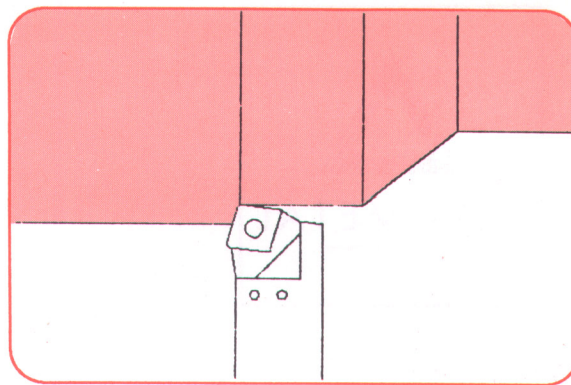

CARTRIDGE - KASSETTE - CARTOUCHE

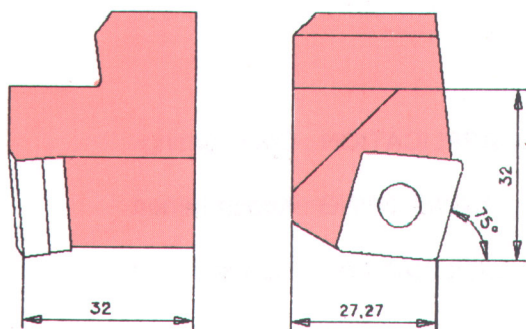

Right hand shown

APPLICATION : Cylindrical turning - Roughing

ANWENDUNG : Zylindrischdrehen-Schruppen

UTILISATION : Chariotage-Ebauche

FOR INSERT
FÜR WENDEPLATTE
POUR PLAQUETTE

ORDER NUMBER
BESTELLNUMMER
NO DE COMMANDE



	RIGHT EXECUTION		LEFT EXECUTION	
CNM . 12 04 ..	C 33533	●	C 33534	●
CNM . 16 06 ..	C 33635	●	C 33636	●
CNM . 19 06 ..	C 33530	●	C 33531	●

● Usually on stock - Gewöhnlich auf Lager
Habituellement de stock

○ On request - Auf Anfrage
Sur demande

SPARE PARTS - ERSATZTEILE - PIECES DETACHEES

FOR INSERT
FÜR WENDEPLATTE
POUR PLAQUETTE

			
CNM . 12 04 ..	32073	32 204	C 26372
CNM . 16 06 ..	32075	32 205	C 26373
CNM . 19 06..	32076	32 206	C 26374

Mounting screw for cartridge : C 23130
Spanschraube für Kasette : C 23130
Vis de pression pour la cartouche : C 23130

- For insert choice see Cérametal turning catalogue
- Für Plattentyp siehe Cérametal Drehkatalog
- Pour le choix des plaquettes voir le catalogue tournage
Cérametal

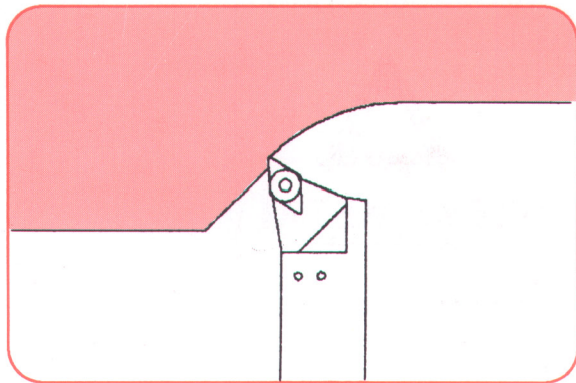

CARTRIDGE - KASSETTE - CARTOUCHE

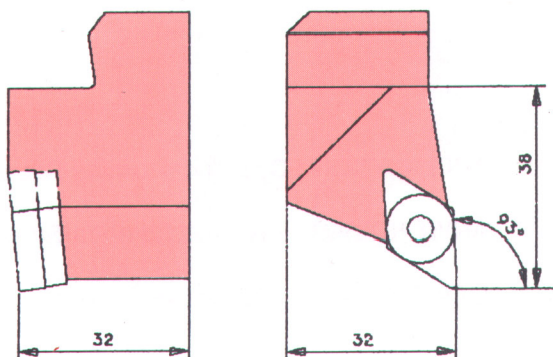

APPLICATION : Copy turning
 ANWENDUNG : Kopierdrehen
 UTILISATION : Copiage

Right hand shown

FOR INSERT FÜR WENDEPLATTE POUR PLAQUETTE	ORDER NUMBER BESTELLNUMMER NO DE COMMANDE			
	RIGHT EXECUTION		LEFT EXECUTION	
DNM . 15 06..	C 35738	●	C 35737	●





Usually on stock - Gewöhnlich auf Lager
 Habituellement de stock



On request - Auf Anfrage
 Sur demande

SPARE PARTS - ERSATZTEILE - PIECES DETACHEES

FOR INSERT FÜR WENDEPLATTE POUR PLAQUETTE			
DNM . 15 06..	32 082	32 214	C 26372

- Mounting screw for cartridge : C 23130
- Spanschraube für Kasette : C 23130
- Vis de pression pour la cartouche : C 23130

- For insert choice see Céramétal turning catalogue
- Für Plattentyp siehe Céramétal Drehkatalog
- Pour le choix des plaquettes voir le catalogue tournage Céramétal

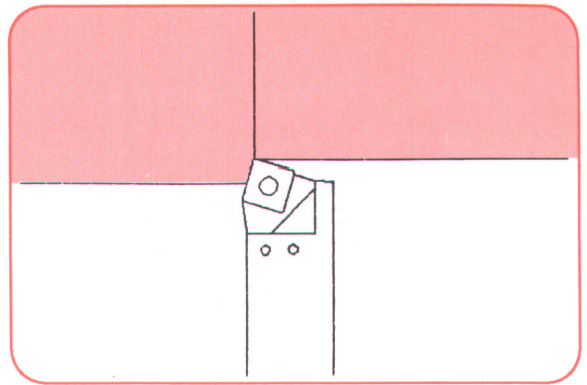

CARTRIDGE - KASSETTE - CARTOUCHE

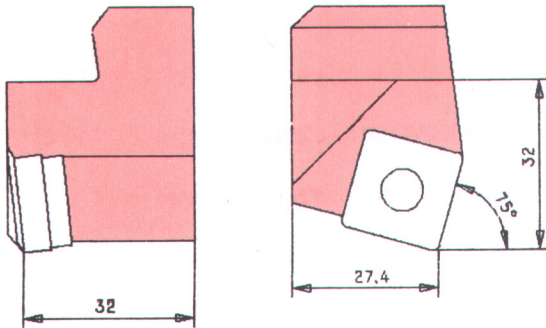

Right hand shown

APPLICATION : Cylindrical turning-Roughing
 ANWENDUNG : Zylindrischdrehen-Schruppen
 UTILISATION : Chariotage-Ebauche

FOR INSERT
 FÜR WENDEPLATTE
 POUR PLAQUETTE

ORDER NUMBER
 BESTELLNUMMER
 NO DE COMMANDE

	RIGHT EXECUTION		LEFT EXECUTION	
SNM . 12 04 ..	C 33555	●	C 33556	●
SNM . 15 06 ..	C 33548	●	C 33549	●
SNM . 19 06 ..	C 33526	●	C 33527	●



Usually on stock - Gewöhnlich auf Lager
 Habituellement de stock



On request - Auf Anfrage
 Sur demande

SPARE PARTS - ERSATZTEILE - PIÉCES DÉTACHÉES

FOR INSERT
 FÜR WENDEPLATTE
 POUR PLAQUETTE



SNM . 12 04 ..	32 053	32 204	C 26372
SNM . 15 06 ..	C 32 053	32 205	C 26373
SNM . 19 06 ..	32 056	32 206	C 26374

- Mounting screw for cartridge : C 23130
- Spanschraube für Kasette : C 23130
- Vis de pression pour la cartouche : C 23130

- For insert choice see Céramétal turning catalogue
- Für Plattentyp siehe Céramétal Drehkatalog
- Pour le choix des plaquettes voir le catalogue tournage Céramétal

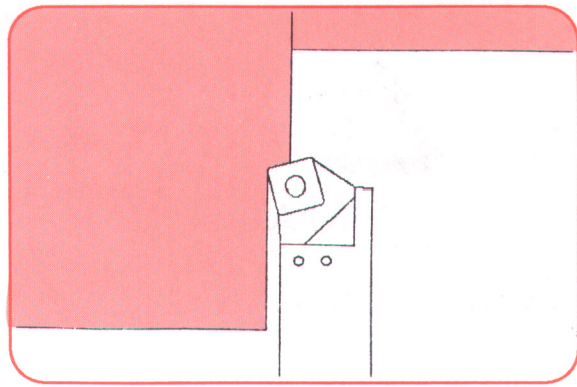

CARTRIDGE - KASSETTE - CARTOUCHE

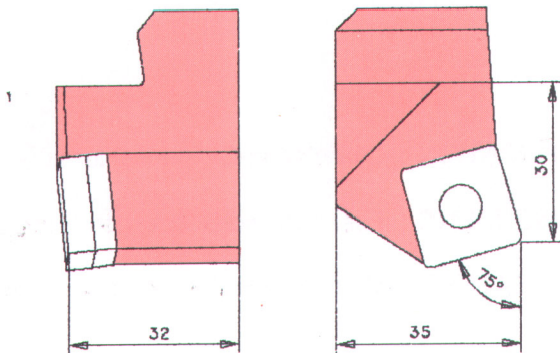

Right hand shown



APPLICATION : Cylindrical turning - Roughing
 ANWENDUNG : Zylindrischdrehen-Schruppen
 UTILISATION : Chariotage-Ebauche

FOR INSERT FÜR WENDEPLATTE POUR PLAQUETTE	ORDER NUMBER BESTELLNUMMER NO DE COMMANDE	
	RIGHT EXECUTION	LEFT EXECUTION
SNM . 19 06..	C 33536 ●	C 33537 ●

● Usually on stock - Gewöhnlich auf Lager
 Habituellement de stock

○ On request - Auf Anfrage
 Sur demande

SPARE PARTS - ERSATZTEILE - PIÈCES DÉTACHÉES

FOR INSERT FÜR WENDEPLATTE POUR PLAQUETTE			
SNM . 19 06 ..	32 056	32 206	C 26374

- Mounting screw for cartridge : C 23130
- Spanschraube für Kasette : C 23130
- Vis de pression pour la cartouche : C 23130

- For insert choice see Céramétal turning catalogue
- Für Plattentyp siehe Céramétal Drehkatalog
- Pour le choix des plaquettes voir le catalogue tournage Céramétal

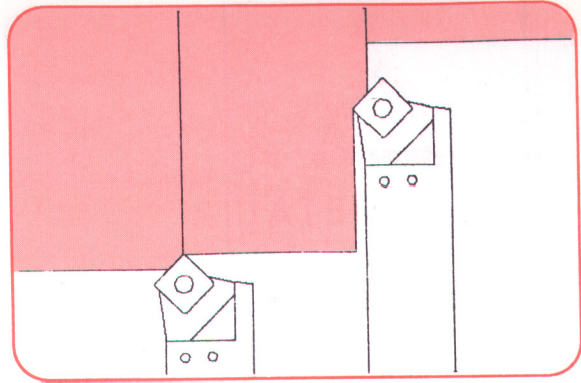

CARTRIDGE - KASSETTE - CARTOUCHE

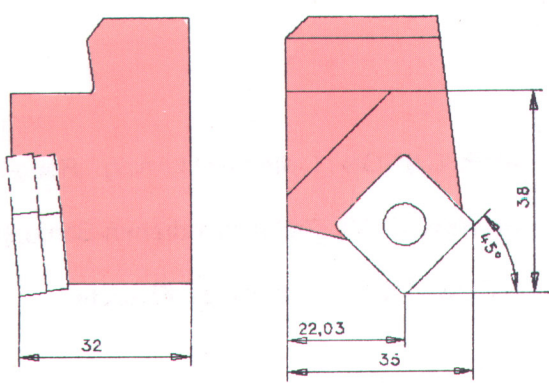

Right hand shown



APPLICATION : Chamfering-Cylindrical turning-Roughing
 ANWENDUNG : Fasen-Zylindrischdrehen-Schruppen
 UTILISATION : Chanfreinage-Chariotage-Ebauche

FOR INSERT FÜR WENDEPLATTE POUR PLAQUETTE	ORDER NUMBER BESTELLNUMMER NO DE COMMANDE	
	RIGHT EXECUTION	LEFT EXECUTION
SNM 19 06 ..	C 32942 ●	C 33538 ●

● Usually on stock - Gewöhnlich auf Lager
 Habituellement de stock

○ On request - Auf Anfrage
 Sur demande

SPARE PARTS - ERSATZTEILE - PIECES DETACHEES

FOR INSERT FÜR WENDEPLATTE POUR PLAQUETTE			
SNM 19 06..	32 056	32 206	C 26374

- Mounting screw for cartridge : C 23130
- Spanschraube für Kasette : C 23130
- Vis de pression pour la cartouche : C 23130

- For insert choice see Céramétal turning catalogue
- Für Plattentyp siehe Céramétal Drehkatalog
- Pour le choix des plaquettes voir le catalogue tournage Céramétal

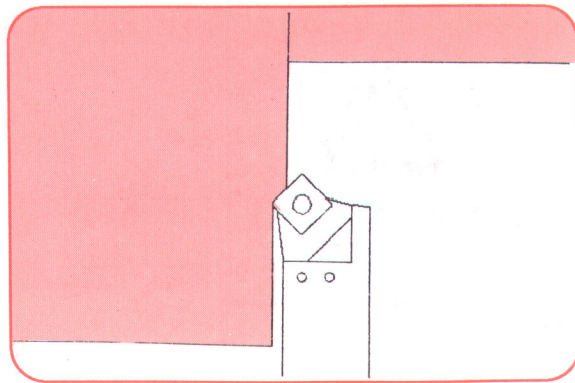
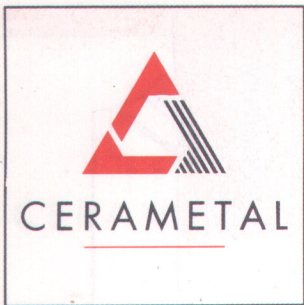

CARTRIDGE - KASSETTE - CARTOUCHE

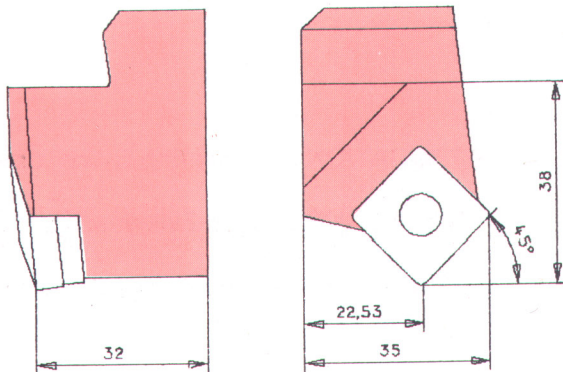

Right hand shown

APPLICATION : -Cylindrical turning-Roughing
 ANWENDUNG : -Zylindrischdrehen-Schruppen
 UTILISATION : -Chariotage-Ebauche

FOR INSERT
 FÜR WENDEPLATTE
 POUR PLAQUETTE

ORDER NUMBER
 BESTELLNUMMER
 NO DE COMMANDE

	RIGHT EXECUTION		LEFT EXECUTION	
SNM . 19 06 ..	C 32946	●	C 33 545	●

● Usually on stock - Gewöhnlich auf Lager
 Habituellement de stock

○ On request - Auf Anfrage
 Sur demande

SPARE PARTS - ERSATZTEILE - PIECES DETACHEES

FOR INSERT
 FÜR WENDEPLATTE
 POUR PLAQUETTE



SNM . 19 06 ..	32 056	32 206	C 26374

- Mounting screw for cartridge : C 23130
- Spanschraube für Kasette : C 23130
- Vis de pression pour la cartouche : C 23130

- For insert choice see Céramétal turning catalogue
- Für Plattentyp siehe Céramétal Drehkatalog
- Pour le choix des plaquettes voir le catalogue tournage Céramétal

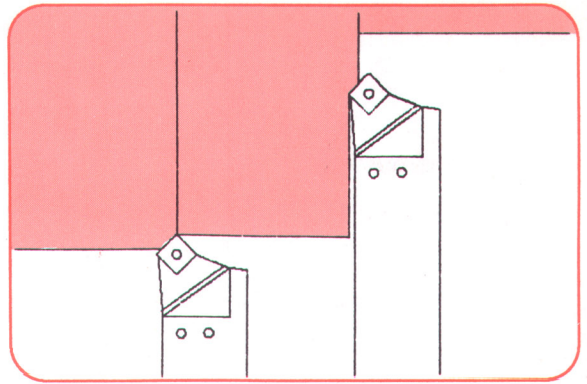

CARTRIDGE - KASSETTE - CARTOUCHE

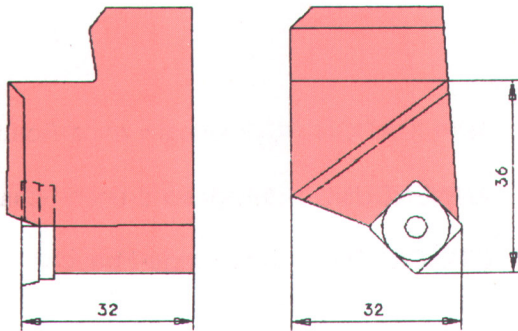

Right hand shown

APPLICATION : Chamfering-Cylindrical turning

ANWENDUNG : Fasen-Zylindrischdrehen

UTILISATION : Chanfreinage-Chariotage

FOR INSERT
FÜR WENDEPLATTE
POUR PLAQUETTE

ORDER NUMBER
BESTELLNUMMER
NO DE COMMANDE

	RIGHT EXECUTION		LEFT EXECUTION	
SCM . 12	C 33528	●	C 33529	●

● Usually on stock - Gewöhnlich auf Lager
Habituellement de stock

○ On request - Auf Anfrage
Sur demande

SPARE PARTS - ERSATZTEILE - PIECES DETACHEES

FOR INSERT
FÜR WENDEPLATTE
POUR PLAQUETTE

SCM . 12 ..



28932



26972



F 4018



No 2

- Mounting screw for cartridge : C 23130
- Spanschraube für Kasette : C 23130
- Vis de pression pour la cartouche : C 23130

- For insert choice see Céramétal turning catalogue
- Für Plattentyp siehe Céramétal Drehkatalog
- Pour le choix des plaquettes voir le catalogue tournage Céramétal

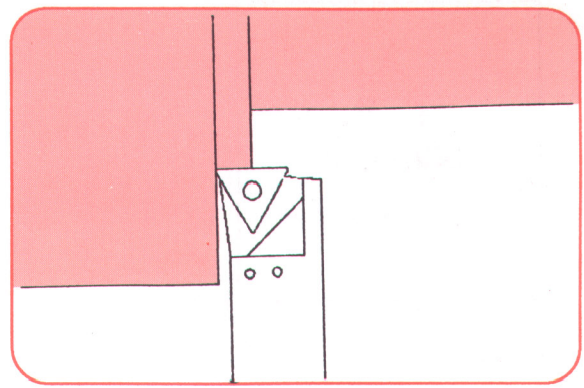

CARTRIDGE - KASSETTE - CARTOUCHE

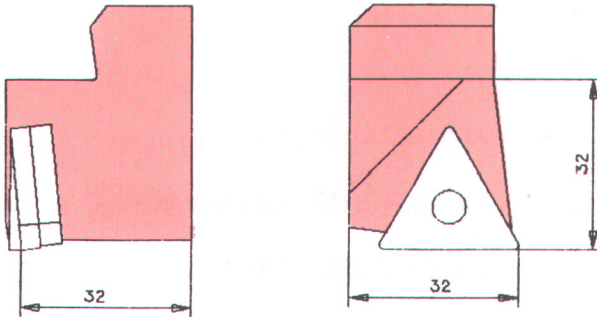

APPLICATION : Face dressing

ANWENDUNG : Flächenabzug

UTILISATION : Dressage face

Right hand shown

FOR INSERT
FÜR WENDEPLATTE
POUR PLAQUETTE

ORDER NUMBER
BESTELLNUMMER
NO DE COMMANDE

	RIGHT EXECUTION		LEFT EXECUTION	
		○		○
TNM 16 03..	C 32943-3	○	C 33600-3	○
TNM 16 04..	C 32943	○	C 33600	○
TNM 22 04..	C 32944	○	C 33543	○



Usually on stock - Gewöhnlich auf Lager
Habituellement de stock



On request - Auf Anfrage
Sur demande

SPARE PARTS - ERSATZTEILE - PIECES DETACHEES

FOR INSERT
FÜR WENDEPLATTE
POUR PLAQUETTE



	32 063	32 212	C 26371
TNM 16 03 ..	32 063	32 212	C 26371
TNM 16 04 ..	32 062	32 212	C 26371
TNM 22 04 ..	32 065	32 204	C 26372

- Mounting screw for cartridge : C 23130
- Spanschraube für Kasette : C 23130
- Vis de pression pour la cartouche : C 23130

- For insert choice see Céramétal turning catalogue
- Für Plattentyp siehe Céramétal Drehkatalog
- Pour le choix des plaquettes voir le catalogue tournage Céramétal

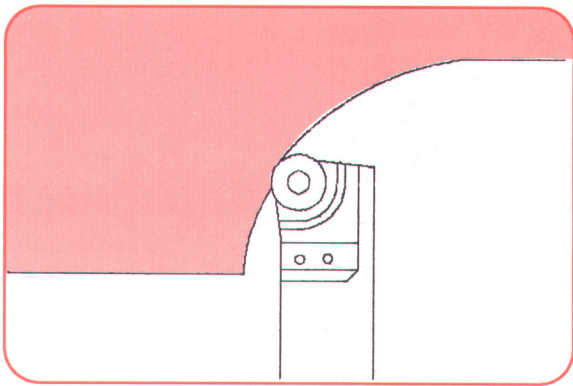

CARTRIDGE - KASSETTE - CARTOUCHE

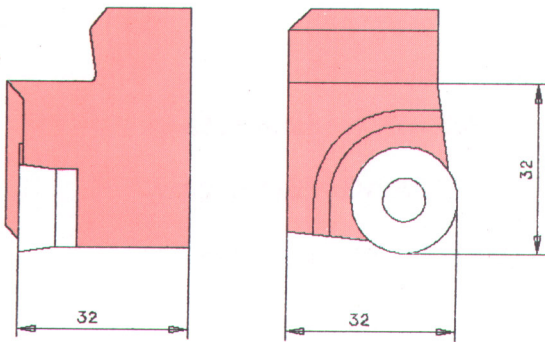

Right hand shown

APPLICATION : Copy turning
 ANWENDUNG : Kopierdrehen
 UTILISATION : Copiage

FOR INSERT FÜR WENDEPLATTE POUR PLAQUETTE	ORDER NUMBER BESTELLNUMMER NO DE COMMANDE			
	RIGHT EXECUTION		LEFT EXECUTION	
RCM. 20 06 M0	C 32939	●	C 33407	●
RCM. 25 07 M0	C 33408	●	C 33409	●

Usually on stock - Gewöhnlich auf Lager
 Habituellement de stock

On request - Auf Anfrage
 Sur demande

SPARE PARTS - ERSATZTEILE - PIECES DETACHEES

FOR INSERT FÜR WENDEPLATTE POUR PLAQUETTE					
RCM. 20 06 M0 ..	30055	30682	D 6018	C 26374	
RCM. 25 07 M0 ..	C34366		F 8025	C 26375	513

- Mounting screw for cartridge : C 23130
- Spanschraube für Kasette : C 23130
- Vis de pression pour la cartouche : C 23130

- For insert choice see Céramétal turning catalogue
- Für Plattentyp siehe Céramétal Drehkatalog
- Pour le choix des plaquettes voir le catalogue tournage Céramétal

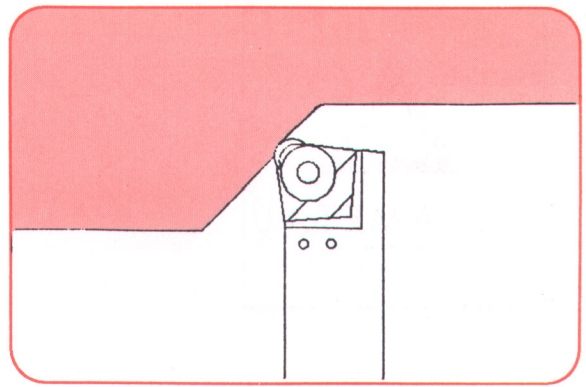

CARTRIDGE - KASSETTE - CARTOUCHE

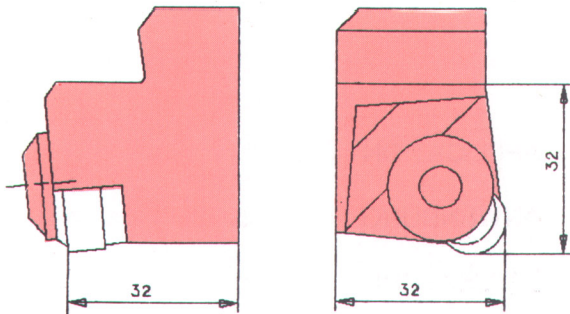

APPLICATION : Finish turning before grinding

ANWENDUNG : Schlichtdrehen vor dem Schleifen

UTILISATION : Finition avant rectification

Right hand shown

FOR INSERT
FÜR WENDEPLATTE
POUR PLAQUETTE

ORDER NUMBER
BESTELLNUMMER
NO DE COMMANDE







	RIGHT EXECUTION		LEFT EXECUTION	
RNGN 12 04 00 CBN	C 33410-4	●	C 33411-4	●
RNGN 12 07 00 CERAMIC	C 33410	●	C 33411	●
RNGN 12 03 00 AMBORITE	C 33410-3	●	C 33410-3	●

● Usually on stock - Gewöhnlich auf Lager
Habituellement de stock

○ On request - Auf Anfrage
Sur demande

SPARE PARTS - ERSATZTEILE - PIECES DETACHEES

FOR INSERT
FÜR WENDEPLATTE
POUR PLAQUETTE

						
RNGN 12 04 00 CBN	C 30542	C 32104	C 21232	C 31941	C 21231-3	C 26375
RNGN 12 07 00 CERAMIC	C 21233	C 32104	C 21232	C 31941	C 21231-3	C 26375
RNGN 12 03 00 AMBORITE	C 33119	C 32104	C 21232	C 31941	C 21231-3	C 26375

- Mounting screw for cartridge : C 23130
- Spanschraube für Kassette : C 23130
- Vis de pression pour la cartouche : C 23130

- For insert choice see Céramétal turning catalogue
- Für Plattentyp siehe Céramétal Drehkatalog
- Pour le choix des plaquettes voir le catalogue tournage Céramétal

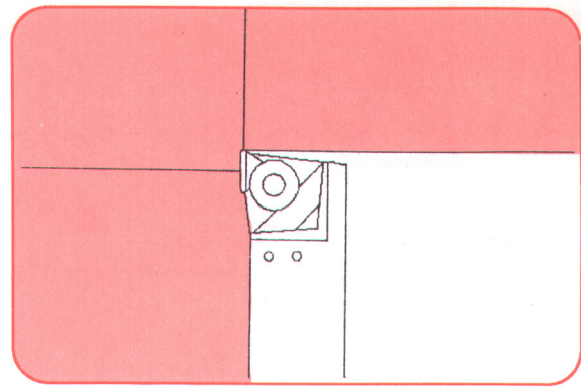

CARTRIDGE - KASSETTE - CARTOUCHE

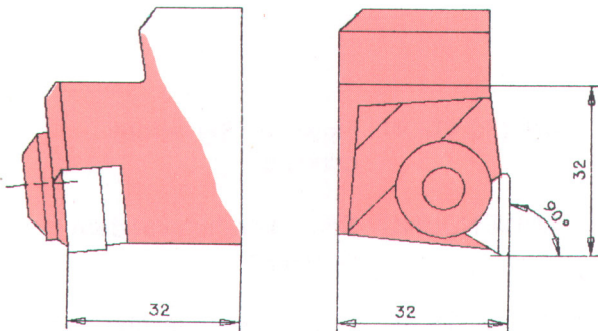

Right hand shown

APPLICATION :

ANWENDUNG :

UTILISATION :

FOR INSERT
FÜR WENDEPLATTE
POUR PLAQUETTE

ORDER NUMBER
BESTELLNUMMER
NO DE COMMANDE







	RIGHT EXECUTION		LEFT EXECUTION	
TNGN 16 04 CBN	C 33541-4	○	C 33542-4	○
TNGN 16 07 CERAMIC	C 33541	○	C 33542	○

● Usually on stock - Gewöhnlich auf Lager
Habituellement de stock

○ On request - Auf Anfrage
Sur demande

SPARE PARTS - ERSATZTEILE - PIECES DETACHEES

FOR INSERT
FÜR WENDEPLATTE
POUR PLAQUETTE

						
TNGN 16 04 CBN	C 33846	C 32104	C 21232	C 21941	C 21238-3	C 26375
TNGN 16 07 CERAMIC	C 21237	C 32104	C 21232	C 21941	C 21238-3	C 26375

- Mounting screw for cartridge : C 23130
- Spanschraube für Kasette : C 23130
- Vis de pression pour la cartouche : C 23130

- For insert choice see Céramétal turning catalogue
- Für Plattentyp siehe Céramétal Drehkatalog
- Pour le choix des plaquettes voir le catalogue tournage Céramétal

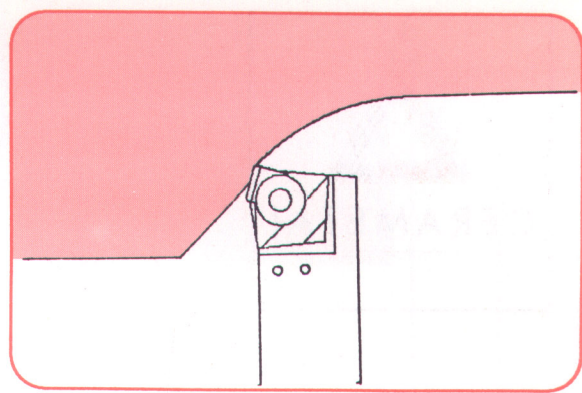

CARTRIDGE - KASSETTE - CARTOUCHE

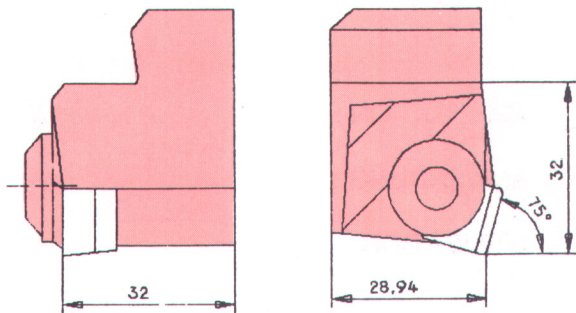

Right hand shown

APPLICATION : Roll neck finish turning

ANWENDUNG : Walzenzapfen Schlichtdrehen

UTILISATION : Finition tourillon

FOR INSERT
FÜR WENDEPLATTE
POUR PLAQUETTE

ORDER NUMBER
BESTELLNUMMER
NO DE COMMANDE

	RIGHT EXECUTION		LEFT EXECUTION	
SNGN 12 07 CERAMIC	C 33539	○	C 33540	○
SNGN 12 03 AMBORITE	C 33539-3	○	C 33540-3	○



Usually on stock - Gewöhnlich auf Lager
Habituellement de stock



On request - Auf Anfrage
Sur demande

SPARE PARTS - ERSATZTEILE - PIECES DETACHEES

FOR INSERT
FÜR WENDEPLATTE
POUR PLAQUETTE



SNGN 12 07 CERAMIC	C 21328	C 32104	C 21232	C 31941	C 21246-3	C 26375
SNGN 12 03 AMBORITE	C 33117	C 32104	C 21232	C 31941	C 21246-3	C 26375

- Mounting screw for cartridge : C 23130
- Spanschraube für Kasette : C 23130
- Vis de pression pour la cartouche : C 23130

- For insert choice see Céramétal turning catalogue
- Für Plattentyp siehe Céramétal Drehkatalog
- Pour le choix des plaquettes voir le catalogue tournage Céramétal

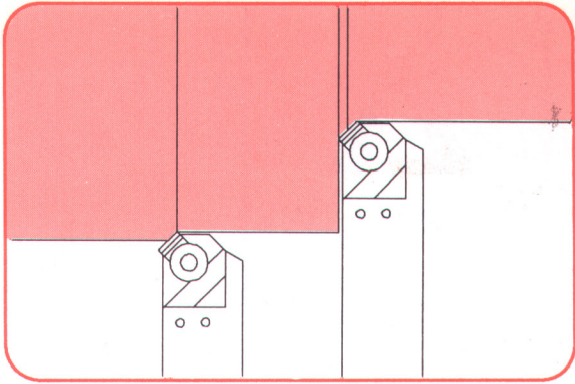

CARTRIDGE - KASSETTE - CARTOUCHE

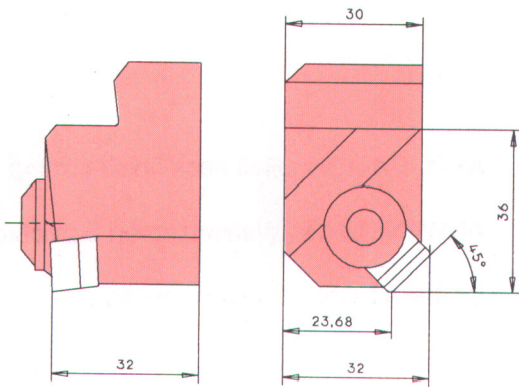

Right hand shown

APPLICATION :
ANWENDUNG :
UTILISATION :

FOR INSERT
FÜR WENDEPLATTE
POUR PLAQUETTE

ORDER NUMBER
BESTELLNUMMER
NO DE COMMANDE

	RIGHT EXECUTION		LEFT EXECUTION	
SNGN 12 07 CERAMIC	C 35740	○	C 35739	○
SNGN 12 03 AMBORITE	C 35740-3	○	C 35739-3	○



Usually on stock - Gewöhnlich auf Lager
Habituellement de stock



On request - Auf Anfrage
Sur demande

SPARE PARTS - ERSATZTEILE - PIECES DETACHEES

FOR INSERT
FÜR WENDEPLATTE
POUR PLAQUETTE



SNGN 12 07 CERAMIC	C 21328	C 32104	C 21232	C 31941	C 21246-3	C 26375
SNGN 12 03 AMBORITE	C 33117	C 32104	C 21232	C 31941	C 21246-3	C 26375

- Mounting screw for cartridge : C 23130
- Spanschraube für Kassette : C 23130
- Vis de pression pour la cartouche : C 23130

- For insert choice see Céramétal turning catalogue
- Für Plattentyp siehe Céramétal Drehkatalog
- Pour le choix des plaquettes voir le catalogue tournage Céramétal

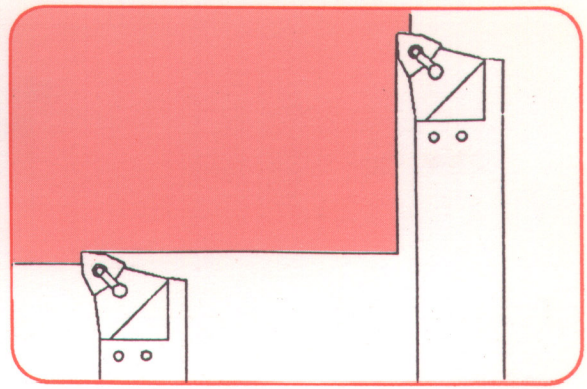

CARTRIDGE - KASSETTE - CARTOUCHE

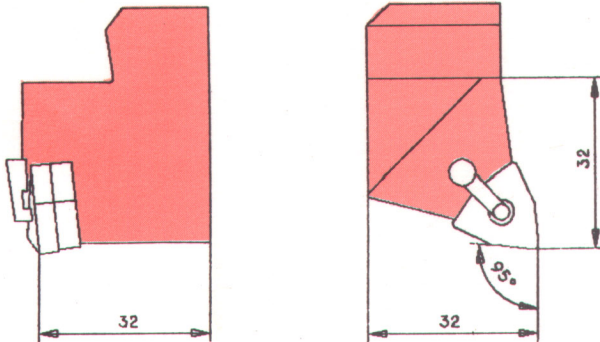

Right hand shown

APPLICATION : -Cylindrical turning

ANWENDUNG :- Zylindrischdrehen

UTILISATION :-Chariotage

FOR INSERT
FÜR WENDEPLATTE
POUR PLAQUETTE

ORDER NUMBER
BESTELLNUMMER
NO DE COMMANDE

RIGHT EXECUTION

LEFT EXECUTION

WNMG 0804..

C 32945



C 33544



Usually on stock - Gewöhnlich auf Lager
Habituellement de stock

On request - Auf Anfrage
Sur demande

SPARE PARTS - ERSATZTEILE - PIECES DETACHEES

FOR INSERT
FÜR WENDEPLATTE
POUR PLAQUETTE



WNMG 0804..

860

8-4

32214

C 26372

- Mounting screw for cartridge : C 23130
- Spanschraube für Kasette : C 23130
- Vis de pression pour la cartouche : C 23130

- For insert choice see Céramétal turning catalogue
- Für Plattentyp siehe Céramétal Drehkatalog
- Pour le choix des plaquettes voir le catalogue tournage Céramétal



CERAMETAL

Members of Céramétal group
Filialen und Werke der Gruppe Céramétal
Usines et filiales du groupe Céramétal
Filialen van de groep Céramétal
Filiale e lavoro il Céramétal

CERAMETAL ET CIE. (8)
DEUTSCHLAND
Hans-Böckler-Straße 12
D-4018 Langenfeld
W.-Germany
Tel. : 0 21 73/7 30 31
Fax : 0 21 73/7 50 27
Tlx : 8515 904 cera d

UNITED HARTMETALL (10)
Postfach 1205
Stadionstraße
D-7240 HORB AM NECKAR
Tel. : 0 74 51/93 336
Fax : 0 74 51/93 274

CERAMETAL GMBH (9)
Am Raesenberg 3
D-3139 Hitzacker
W.-Germany
Tel. : 0 58 62/10 01
Tlx : 91 558

CERAMETAL IBERICA (6)
Calle San Vicente 8
EDIFICIO ALBIA 1, PLANTA 2
E-4800 J BILBAO
Tel. : (94) 423 7118
Fax : (94) 423 9718

CARBIDE ALLOYS INC.
Post Office Box 44
Columbia, South Carolina,
29202 USA
Tlx : 8106662114

C. W. CARBIDES LTD. (5)
Lawson-Hunt Ind. Park
Unit 5, Broadbridge Heath
Horsham, W. Sussex RH12 3JR
Tlx : 877141

CERATOOL S.A.R.L. (1)
Rue de Bettembourg
L-3378 Livange
LUXEMBOURG
Tlx : 2540

CERATUNGSTEN (1)
Zone Industr. Hâneboesch
Rte de Bascharage
L-4513 Niederkorn
LUXEMBOURG
Tlx : 2540

CYLCARB S.A. (1)
Route de Holzem
L-8201 Mamer
LUXEMBOURG
Tlx : 2540

CERADUR FRANCE (3)
32, Avenue Marcel Cachin
F-69120 Vaulx-en-Velin
FRANCE
Tlx : 306027

BIDURIT HARTMETALL AG (2)
Solothurnstrasse 1
CH-2500 Biel 6
Tel. : 032/42 39 36
Fax : 032/42 51 12

DURAMET CORP.
11350 Stephens Dr.
WARREN, MI 48089/USA
Tel. : (313) 759-2280
Fax : (313) 759-1657

CERAMETAL ITALIA (7)
1, Via Barbarani
I-37036 San Martino B. A.,
Verona, ITALIA
Tlx : 481226

CERAMETAL NEDERLAND (4)
Albertdonk, 2
NL-4707 XZ Roosendaal
NEDERLAND
Tlx : 78019
Tel. : 0 16 50-5 08 00
Fax : 0 16 50-5 61 76

CERAMETAL & CIE. (1)
Route de Holzem · L-8201 Mamer/Luxembourg · Tél. : 31 20 85-1 · Telex : 2540 Ceralu · Téléfax : 31 19 11 Gr.3

